

NTG160128C Graphic 160x128 dots

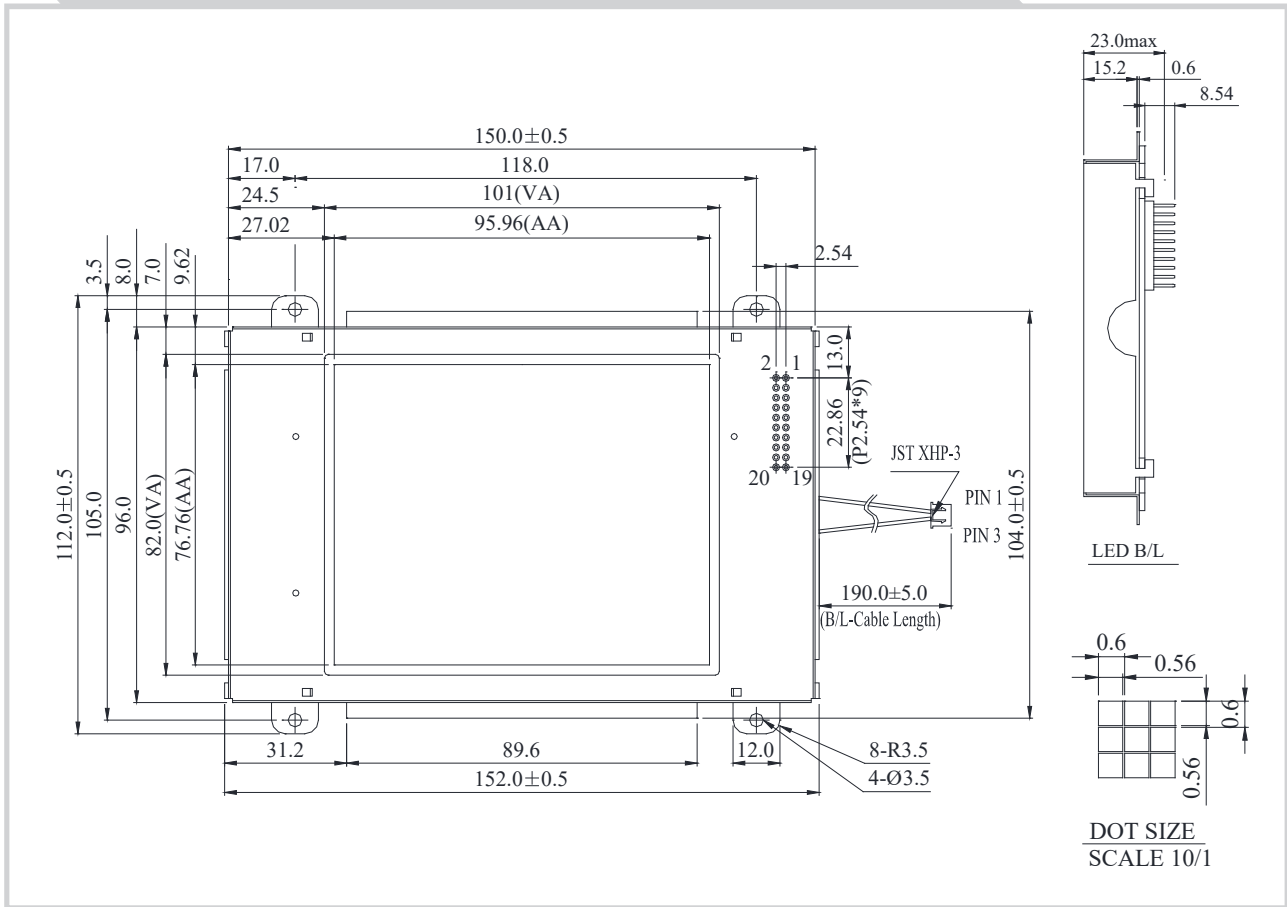

Feature

1. Built-in controller RA6963
2. 5V power supply
3. 1/128 duty cycle
4. Optional N/V

Pin No.	Symbol	Description
1	FG	Frame ground
2	Vss	Ground
3	Vdd	Power supply for logic
4	Vo	Contrast Adjustment
5	Vee	Negative Voltage Output
6	/WR	Data write. Write data into LCD Controller
7	/RD	Data read. Read data from LCD Controller
8	/CE	Enable signal
9	C/D	Data/ Instruction select signal
10	/HALT	Clock operating stop signal
11	/RESET	Controller reset signal, Active Low
12	DB0	Data bus line
13	DB1	Data bus line
14	DB2	Data bus line
15	DB3	Data bus line
16	DB4	Data bus line
17	DB5	Data bus line
18	DB6	Data bus line
19	DB7	Data bus line
20	NC	No connection

Mechanical Data

Item	Standard Value	Unit
Module Dimension	150.0 x 112.0	mm
Viewing Area	101.0 x 82.0	mm
Mounting Hole	118.0 x 105.0	mm
Dot Pitch	0.60 x 0.60	mm
Dot Size	0.56 x 0.56	mm

Electrical Characteristics

Item	Symbol	Standard Value	Unit
		typ.	
Input Voltage	VDD	3/5	V
Recommended LCD Driving Voltage for Normal Temp. Version module @25°C	VDD-VO	18.95	V